

REGULATORY ASSISTANCE PROJECT

Good COP/Bad COP: Balancing fabric efficiency, flow temperatures and heat pumps

A case study of the Irish HLI requirements

Dr. Richard Lowes

Contents

Executive summary.....	2
1. Introduction	3
2. Lower flow temperatures: The difference between heat pumps and combustion	5
3. Low(er) temperature heating can heat almost any building, but care is needed.....	8
3.1. Heat pump sizing.....	9
3.2. Emitter sizing.....	9
3.3. Possible wider innovation.....	10
3.4. Understanding and increasing in-practice performance.....	11
3.5. Closing the performance gap.....	13
4. The history of the HLI.....	14
4.1. Fabric performance standards for heat pump grants elsewhere	16
5. Energy efficiency and cost-optimality	17
5.1. The importance of energy efficiency.....	17
5.2. Cost-optimality and HLI level	18
5.3. Cost-optimality in the context of decarbonisation	19
5.4. Systemwide impacts and considerations.....	22
5.5. Heat pump running costs	23
5.6. Section summary.....	24
6. The impact of HLI on heat pump bills.....	25
7. Conclusions.....	27

Executive summary

Heat pumps are widely recognised as the key technology to decarbonising building heat demand in Ireland and they can significantly reduce fuel imports. They are currently supported by grants for homeowners but to receive grants for heat pumps, households in Ireland are required to have a heat demand per unit of floor area,

known as a 'heat loss indicator' (HLI), below a certain level. The HLI requirement was designed to protect households from high bills if they switched to a heat pump.

There is a concern that the HLI is limiting heat pump deployment, a technology which is seen as central to Ireland's net zero goals. A review of the HLI policy and associated rules was undertaken alongside a discussion of heat pumping technologies and their operation, optimal performance and innovation.

The combined issues of heat pump performance, building efficiency and running costs are a complex and technical policy concern which can have major implications for homeowners and the energy system. Yet fabric efficiency standards associated with heat pump grants, like the HLI requirement, are not common in other countries. Despite the continued use of the HLI, modelling undertaken on behalf of the Irish government suggests that for HLI levels outside of current heat pump grant requirements, a heat pump with a coefficient of performance (COP) level of 3 (an average performance) may be cheaper to run than oil and mains gas.

Furthermore, heat pump technologies have, and continue to innovate, to give better in-use efficiencies alongside higher output temperatures meaning that they may be able to more easily replace combustion-based technologies than has been previously assumed. This is not to say that fabric energy efficiency retrofits are not needed, but it does imply that the depth and number of retrofits needed may be reduced.

The innovation in heat pump performance, alongside the falling price of renewable electricity generation and the high price of fossil fuel alternatives, means heat pumps are increasingly cost-effective and have become easier to retrofit. Our review makes four main policy recommendations:

1. The continued use of the HLI may not be the best metric to protect consumers while rapidly deploying heat pumps. In the short term, the HLI threshold could simply be increased, as planned in the Sustainable Energy Authority of Ireland field trial, alongside appropriate consumer and installer engagement measures.
2. In the longer term, a focus on flow temperatures or heat pump performance alongside necessary consumer protections and redress options would be more appropriate.

Acronyms

- BOC: Byrne Ó Cléirigh
- CODE: Cost-optimal domestic electrification
- COP: Coefficient of performance
- EPBD: Energy Performance of Buildings Directive
- HLI: Heat loss indicator
- IRR: Internal rate of return
- MCS: Microgeneration Certification Scheme
- NHS: National heat study
- SCOP: Seasonal coefficient of performance
- SEAI: Sustainable Energy Authority of Ireland
- SWI: Solid wall insulation

3. On energy efficiency requirements for heat pump support grants, a simpler metric based on minimum requirements (such as all walls being insulated) may be more appropriate. However, this should not detract from a longer-term energy efficiency focus. When considering the optimum energy efficiency levels of buildings, greater attention should be paid to key future heating technologies, such as heat pumps and heat networks. Alongside EU-required, technology-neutral cost-optimal calculations, further calculations should be considered which determine cost-optimality of building fabric efficiency specifically for building decarbonisation.
4. Our review notes that evidence on the actual performance of heat pumps in Ireland is currently extremely limited. Continued heat pump trials, evidence gathering and analysis will provide extremely valuable evidence to support optimal deployment policy as the sector rapidly innovates. Reviews into the appropriateness of HLI levels (up to HLI 3) should be expedited.¹

1. Introduction

The energy used to heat Irish buildings is responsible for around a quarter of the nation's greenhouse gas emissions. With a goal of reaching net zero by 2050, and tough interim targets, rapid and sustained progress is needed on heat decarbonisation and energy efficiency. As shown in Figure 1, the largest share of energy used for heating buildings is that within residential buildings.² Oil currently dominates the heat used in buildings, with gas in second place. While most new homes (80% between 2020 and 2022) use electricity for heating, often with heat pumps,³ rapid progress is needed for existing buildings.

Figure 1. Total annual heating demand (GWh/annum), by sector

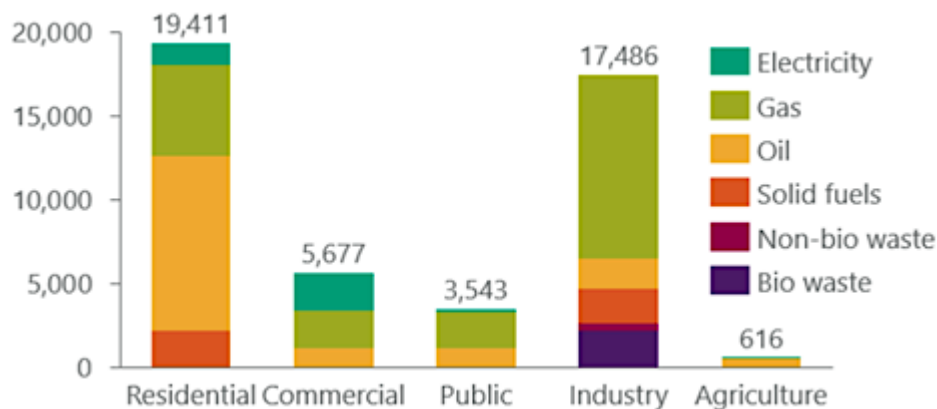

Source: SEAI. (2022a, February). *Heating and cooling in Ireland today: Archetype Profiles, Spatial Analysis, and Energy Efficiency Potential*.

¹ The author of this paper would like to thank the following: The Government of Ireland and the Sustainable Energy Authority of Ireland for their guidance and knowledge and to external reviewers, which includes Nicola Terry. Thanks to internal reviewers Louise Sunderland, Duncan Gibb, Samuel Thomas, Jan Rosenow, Tim Simard and Steena Williams. The views in this report reflect the views of the author only.

² SEAI. (2022a, February). *Heating and cooling in Ireland today: Archetype Profiles, Spatial Analysis, and Energy Efficiency Potential*. <https://www.seai.ie/publications/Heating-and-Cooling-in-Ireland-Today.pdf>

³ Central Statistics Office. (2022, April). *Domestic Building Energy Ratings, Quarter 1 2022*. <https://www.cso.ie/en/releasesandpublications/er/dber/domesticbuildingenergyratingsquarter12022/>

As highlighted by the recent National Heat Study and shown below in Figure 2, heat pumps are expected to dominate the future Irish heat mix under a balanced scenario.⁴ As such, Ireland has an explicit goal for rapid heat pump deployment, with a target of 400,000 heat pumps installed into existing homes by 2030.⁵ There are very few scalable low-carbon heat options, and for houses with no connection to the gas grid, heat pumps appear indispensable. For houses on the gas grid, despite a little more uncertainty and while district heating is expected to play a role in urban areas, heat pumps are still anticipated to be central in reaching net zero.

Figure 2. Residential heating demand breakdown, by fuel and technology (balanced, TWh)

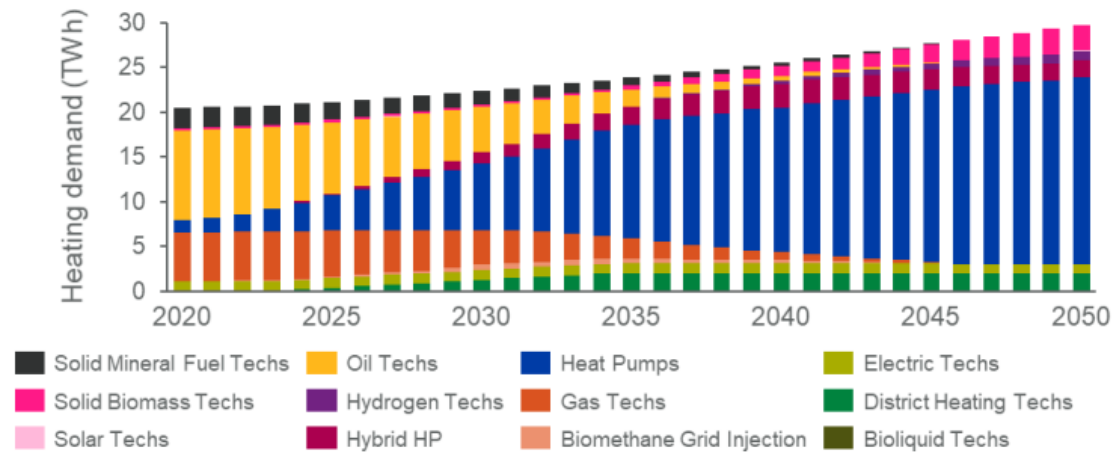

Source: SEAI. (2022b, February). *Net Zero by 2050: Exploring Decarbonisation Pathways for Heating and Cooling in Ireland*.

Currently, Irish government policy is that for heat pump grants offered to homes, a building must not have a heat loss indicator (HLI) level above 2, although in some circumstances this can be 2.3. The HLI is a metric representing the heat loss of a building per unit of floor area, and the metric is produced during the Dwelling Energy Assessment Procedure.

Recognising the critical role of fabric efficiency for reducing energy demand and carbon emissions as well as lowering running costs, the HLI requirement was developed to protect consumers from high bills and the possibility of poor heat pump performance in the least efficient buildings. However, analysis suggests that heat pumps will be cheaper to run than gas and oil heating, even in buildings outside the current HLI threshold.⁶

⁴ SEAI. (2022b, February). *Net Zero by 2050: Exploring Decarbonisation Pathways for Heating and Cooling in Ireland*. <https://www.seai.ie/publications/Net-Zero-by-2050.pdf>

⁵ Government of Ireland. (2022, February). *National Retrofit Plan*. <https://www.gov.ie/en/publication/5052a-national-retrofit-plan/>

⁶ SEAI. (2018). *Better Energy Homes: Heat Loss Indicator* [Presentation]. Shared directly with RAP.

Analysis shows that significant increases in policy effort are required for heat pump deployment in Ireland to meet government targets.⁷ The HLI appears to be one such area where efforts are needed, with Ireland's Climate Council suggesting that heat loss indicator requirements should be widened and better communicated to facilitate roll-out to a larger number of homes,⁸ a suggestion that also inspired this paper.

The suggested loosening or modification of the HLI rule comes as technological innovation means that heat pumps are getting better at heating less efficient buildings⁹ and amidst a wider discussion on the optimal level of fabric energy efficiency needed for heat pumps and heat decarbonisation in general.

This briefing examines all these issues and considers whether the current policy in Ireland should be modified. Overall, we think this element of policy could be reformed using:

- A relaxation or widening of the HLI criteria in the short term.
- Over the longer term and based on more detailed technical analysis, the HLI criteria could be replaced by a flow temperature standard alongside minimum energy efficiency standards for buildings based on specific fabric measures.

RAP has been working directly on energy efficiency policy for many years and recognises it as key to the energy transition; indeed, RAP has championed the efficiency first principle in the EU since 2014.¹⁰ As such, we recognise that significant efforts are needed to increase the efficiency of the building stock alongside the roll-out of heat pumps. However, one policy area should not be holding another back, and reform of the HLI could support more rapid and cost-effective removal of fossil fuel heating.

2. Lower flow temperatures: The difference between heat pumps and combustion

Combusting a fuel, be it oil, biomass or gas, generates heat at well over 100°C. As a result, combustion-based heating technologies warm their transport medium – water, in the case of much of Europe (although air-based systems are prevalent elsewhere) – to a relatively high temperature, generally above 60°C. The temperature of water flowing in pipes and radiators is known as the flow temperature.

⁷ SEAI, 2022b.

⁸ Martin, T.M., Varadkar, T.L. & Ryan, E. (2022, April 12). *RE: Energy Security and Climate Action* [Memo]. Climate Change Advisory Council. <https://www.climatecouncil.ie/media/climatechangeadvisorycouncil/contentassets/documents/news/CCAC%20Letter%20to%20Government.pdf>

⁹ BEIS. (2021, February). *Cost Optimal Domestic Electrification (CODE)*. <https://www.gov.uk/government/publications/cost-optimal-domestic-electrification-code>

¹⁰ Cowart, R. (2014, December). *Unlocking the Promise of the Energy Union: "Efficiency First" is Key*. Regulatory Assistance Project. <https://www.raonline.org/knowledge-center/unlocking-the-promise-of-the-energy-union-efficiency-first-is-key/>

It is worth noting that, for the proper performance of condensing boilers (i.e. when they are condensing), a lower flow temperature should be used to ensure that the water vapour in the exhaust gas condenses fully, thus meeting their ‘nameplate’ boiler efficiency.¹¹ The lower the flow temperature, the more efficient a condensing boiler will be; a flow temperature of 50°C is suggested to get a gas boiler to over 90% efficiency.¹² It is worth noting that the UK government has just added a consideration in English building regulations to lower flow temperatures in all homes when building work takes place or heating system modifications are made.¹³

Heat pumps use electricity to extract heat from environmental sources. Naturally, the bigger the temperature difference between the source (say, the ground or the air) and the target flow temperature, the more electricity is used by the heat pump and the lower its coefficient of performance (COP), the key metric for the performance of heat pumps.

COP is a measure of how many units of usable heat a heat pump can output compared to how many units of electricity it uses. A COP of 4 means one unit of electricity is used for four units of heat outputted. A rough estimate of COPs versus temperature difference is shown in Figure 3.¹⁴

Figure 3. Approximate COP versus temperature differential

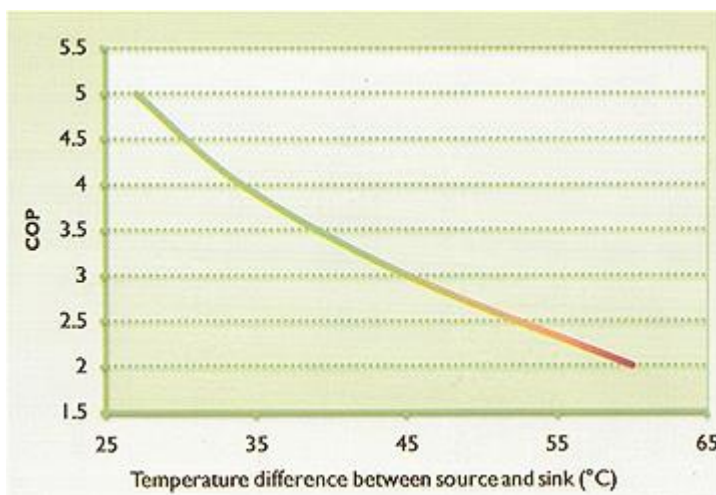

Source: Cantor, J. (2021). *Heat Pumps for the Home*, 2nd Edition. Crowood Publishing.

¹¹ Alsop, J. (2021, October 18). Save 9% in gas use, by turning down the ‘flow’ temperature. *The Heating Hub*. <https://www.theheatinghub.co.uk/articles/turn-down-the-boiler-flow-temperature>

¹² Heat Geek. (2018, November). *Condensing theory - How do condensing boilers add efficiency?* <https://www.heatgeek.com/condensing-boilers-efficiency/>

¹³ ‘Where a wet heating system is either: a. newly installed b. fully replaced in an existing building, including the heating appliance, emitters and associated pipework, all parts of the system including pipework and emitters should be sized to allow the space heating system to operate effectively and in a manner that meets the heating needs of the dwelling, at a maximum flow temperature of 55°C or lower.’ From: Government of UK. (2021). *The Building Regulations 2010: Conservation of fuel and power*. Volume 1: Dwellings. https://assets.publishing.service.gov.uk/government/uploads/system/uploads/attachment_data/file/1057372/ADL1.pdf

¹⁴ Cantor, J. (2021). *Heat Pumps for the Home*, 2nd Edition. Crowood Publishing. Source refers to where the heat is being moved from and sink refers to where the heat is ending up, for example, radiators. Reprinted with permission.

In practice what this means is that the lower the flow temperature (or the higher the external temperature), the higher the COP, and a higher COP means lower running costs because less electricity is needed. Through lowering flow temperatures, a heat pump can output an equivalent amount of useful heat but use less energy to do so.

COPs are also likely to be lower in winter than summer because the temperature difference between required flow temperature and source temperature will be greatest when it is coldest. What this means for homeowners is that energy use with a heat pump may fluctuate more significantly across the year compared to fossil fuel heating. Even if annual running costs remain the same, bills could be lower in summer and higher in winter. It worth noting, however, that direct debit customers tend to pay a set amount each month to cover annual costs.

Modern heat pumps (and many boilers, if enabled) use weather compensation to alter the flow temperature depending on the external temperatures, as higher flow temperatures are needed in colder conditions. This has the effect of minimising the average temperature difference and therefore maximising COP across the year.

The seasonal coefficient of performance (SCOP) is the average performance of a heat pump over a year and is the key metric needed to calculate heat pump running costs. SCOP can also take into account other electricity uses associated with the heat pump, such as circulation pumps and supplementary heating. Care should be taken when using COPs and SCOPs during analysis because of:

1. Their importance in calculations and energy system modelling. The difference between a COP of 3 and 3.1 could have a significant energy system and cost impact.
2. The fact that heat pump manufacturers have been innovating. SCOPs are increasing,¹⁵ and analysis becomes outdated quickly if based on older technologies and systems which are less efficient.
3. Calculations may take into account other heat system energy demands, such as circulation pumps, which would also be needed in fossil fuel heating systems.

¹⁵ Delmastro, C. (2022, September). *Heat pumps*. IEA. <https://www.iea.org/reports/heat-pumps>

With regard to point 3, Figure 4 shows the various ‘H’ boundaries which can be used to calculate heat pump SCOPs.¹⁶ H4 includes circulation pumps, which are used by all hydronic (water-based) heating systems, and it is easy to see how care should be taken when comparing SCOPs with other technologies. As such, for comparing heat pumps to fossil fuel technologies, the H3 boundary as shown below is likely to be of most use.

Figure 4. System boundaries used for COP/SCOP calculations (NB: ‘Boost’ is for pasteurization cycle)

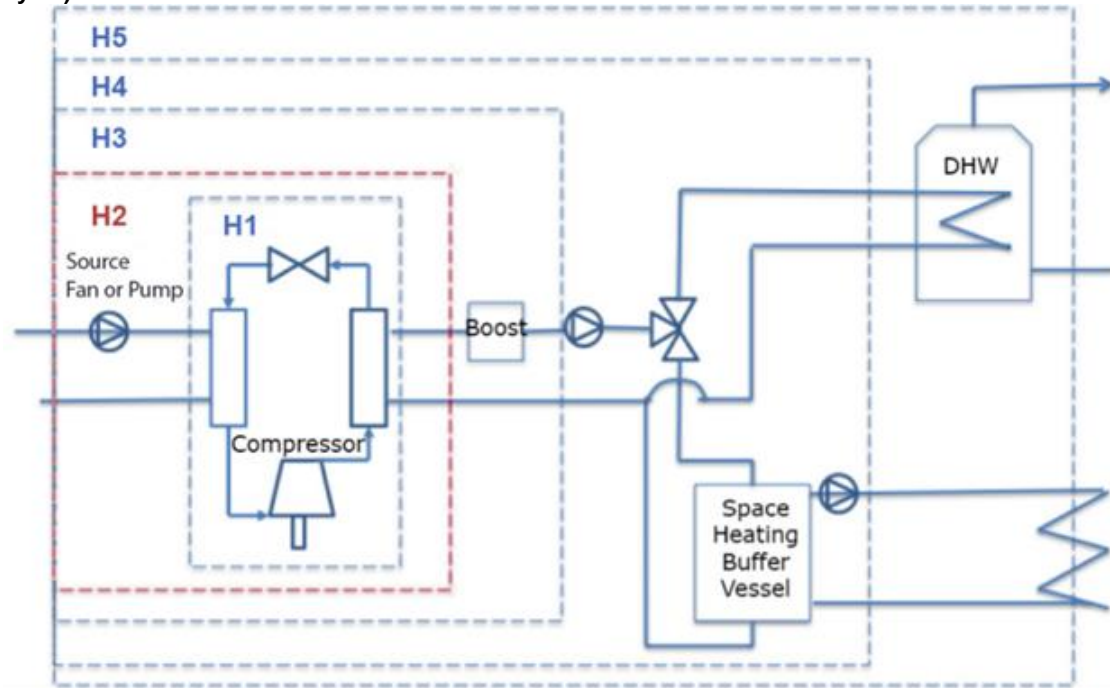

Source: Summerfield, A., Biddulph, P., Stone, A., Grainger, C., Agnolucci, P., Gleeson, C., Oikonomou, E. & Lowe, R. (2016, January). *Analysis of data from heat pumps installed via the renewable heat premium payment (RHPP) scheme to the Department of Energy and Climate Change (DECC)*. UCL Energy Institute.

3. Low(er) temperature heating can heat almost any building, but care is needed

As heat pumps work at lower flow temperatures than boilers, considerations before and during an installation are different. In this section, we introduce the importance of heat pump and emitter sizing and also consider innovation in the heat pump market. This section goes on to consider the sometimes limited in situ data on heat pump performance and then discusses how the best performance can be achieved.

¹⁶ Summerfield, A., Biddulph, P., Stone, A., Grainger, C., Agnolucci, P., Gleeson, C., Oikonomou, E. & Lowe, R. (2016, January). *Analysis of data from heat pumps installed via the renewable heat premium payment (RHPP) scheme to the Department of Energy and Climate Change (DECC)*. UCL Energy Institute. https://assets.publishing.service.gov.uk/government/uploads/system/uploads/attachment_data/file/606778/DECC_RHPP_160112_Detail_analysis_report_v5.3.pdf

3.1. Heat pump sizing

It is often suggested that heat pumps cannot heat the most inefficient buildings. However, the reality is that a heat pump can be used in any building but needs to be specified, sized and installed correctly. The heat pump sizing needs to ensure that the heat pump itself is large enough to meet the peak heat demand; that is, the highest instantaneous heat output needed from the heat pump to heat the house to a comfortable temperature on the coldest day (measured in kW). A less efficient building (with a higher HLI) will need a bigger heat pump and bigger emitters (i.e. radiators or underfloor heating) to achieve the same flow temperatures and therefore COP compared to a more efficient building of the same size.

An extreme example of a heat pump in an inefficient building is the use of a ground-source system in an eleventh-century church in Kent — a totally uninsulated, thousand-year-old building.¹⁷ Whilst technically it is possible to heat any building with a heat pump, the running costs are, of course, a very important consideration, and suitable, cost-effective energy efficiency measures should ideally be installed before, as part of or after the heat pump install.

A heat pump will not be working at maximum capacity all the time. However, a bigger heat pump is needed to meet the higher instantaneous heat demand in colder weather. Heat pumps used to be very inefficient when operating at part load because they could only do this by cycling on and off. Modern heat pumps use inverters to modulate the compressor speed. This means that if a heat pump is installed and fabric efficiency measures added later, the oversized heat pump is less likely to suffer from poor performance.¹⁸

3.2. Emitter sizing

Installers and engineers who design and specify heating systems (often the same people) also need to ensure that the emitters (radiators or underfloor heating) are sized correctly to run at lower flow temperatures; this is done most accurately on a room-by-room basis. In some cases, existing radiators on fossil fuel systems are often bigger than necessary (oversized) which means that the required heat output can be achieved at lower flow temperatures, and therefore they do not need to be replaced. However, in many situations, emitters will need to be upgraded with the size of the radiator, dependent on the specific heat demand of the room. Pipework may need to be upgraded too, as lower flow temperatures mean water needs to flow faster to deliver the same amount of heat.

Reducing the flow temperatures in a radiator from 70°C to 50°C would reduce the maximum heat output by just under half.¹⁹ Assuming the radiators were sized for 70°C, such a drop in output would therefore require a doubling of radiator capacity. Naturally, the less efficient the building, the higher the required output from radiators.

¹⁷ ISO Energy. (n.d.). *St. Stephen's Church*. <https://www.isoenergy.co.uk/projects/st-stephens-church>

¹⁸ Salts, N. & Groll, E. (2017, May). *O. 1.5.2 Inverter Drive Control and Seasonal Performance Analysis of a Single Speed Unitary Air-Source Split-System Heat Pump*. Heat Pump Technologies. <https://heatpumpingtechnologies.org/publications/o-1-5-2-inverter-drive-control-and-seasonal-performance-analysis-of-a-single-speed-unitary-air-source-split-system-heat-pump/>

¹⁹ Stelrad. (n.d.). *Technical information*. https://www.stelrad.com/wp-content/uploads/2014/08/stelrad_technical_info.pdf

While existing radiators may still be suitable for use at lower flow temperatures, if radiators are replaced, rather than taking up wall space with longer or taller radiators, they can be made deeper to achieve higher outputs. Of course, in some retrofit projects, householders may choose underfloor heating, which tends to be run at lower flow temperatures than radiators. It should be noted that in dwellings which have particularly high heat losses combined with small footprints, achieving low flow temperatures can be challenging because of the number and size of radiators needed.

3.3. Possible wider innovation

We have primarily been discussing hydronic heating systems which use water as a heat transfer medium. It is worth noting that air-to-air heat pumps, also known as reversible air conditioners (found in many hotel rooms, shops and offices) may be particularly suitable for inefficient buildings. These systems heat the air, generally producing lower output temperatures than in a wet system, and can achieve good COPs without the need for wet central heating, thus eliminating the need for large radiators which may otherwise be needed. An air-to-air heat pump listed on the Danish heat pump database can achieve a measured COP of 6.2, but in situ measured performance of air-to-air heat pumps is limited.

Air-to-air heat pumps can also be used more intermittently due to their high, instantaneous hot-air output (i.e. they can warm spaces quickly). This means that they may be particularly suited to situations where the building is not kept warm all the time, something which may be more cost-effective for less efficient buildings.

Finally, the heat pump market is innovating with a focus on increasing performance while at the same time improving the sustainability of refrigerants. One notable product is the Vaillant AroTHERM Plus heat pump (shown below in Figure 5) — it uses refrigerant R290, which is propane. Vaillant reports COPs above 3 even with flow temps of 55°C, and the unit can achieve output temperatures of 75°C, thus eliminating the need for resistive heat use for pasteurisation cycles.²⁰ Ireland-based Grant's²¹ Aerona heat pumps can, according to the manufacturer, reach similar COPs as the Vaillant model at the same flow temperatures, although this model uses refrigerant R32, which has a higher global warming impact than R290 if it leaks.

Figure 5. A Vaillant AroTHERM Plus air-source heat pump



Source: Vaillant Group. (n.d.). *aroTHERM Plus technical information*. Reprinted with permission.

3.4. Understanding and increasing in-practice performance

Despite the need for a rapid roll-out of heat pumps, measured in situ performance of heat pumps in retrofit applications is limited, in part by a lack of studies but also because of the time gap between a heat pump product being developed and suitable data being produced and analysed. In Ireland, heat pump performance data seems particularly limited.

²⁰ Vaillant Group. (n.d.). *aroTHERM Plus technical information*. <https://www.vaillant.co.uk/downloads/aproducts/renewables-1/arothem-plus/arothem-plus-spec-sheet-1892564.pdf>

²¹ BEIS. (2020, November). *Heat pump manufacturing supply chain research project*. https://assets.publishing.service.gov.uk/government/uploads/system/uploads/attachment_data/file/943712/heat-pump-manufacturing-supply-chain-research-project-report.pdf

Optimism can be taken from the fact that good performance in retrofit situations is clearly possible, with recent German retrofit studies showing average SCOPs of 3.1 for air-source and 4.1 for ground-source heat pumps.²² Fraunhofer also reports SCOPs of 3 for air-source and 3.7 for ground-source heat pumps in buildings with uninsulated walls.²³ The Irish Superhomes project demonstrated SCOPs above 3 for all installations and even up to 4 in retrofit applications with air-source heat pumps.²⁴

Elsewhere, the picture is not always as optimistic. In the UK, a 2010 publication by the Energy Saving Trust showed that while both air-source and ground-source heat pumps could achieve SCOPs above 3, these were in the minority, and performance varied significantly between 1.2 and 3.3.²⁵ It should be noted that these heat pumps were installed before 2008 in an extremely immature market before the existence of the Microgeneration Certification Scheme (MCS) governing body. Further monitoring of and modifications to some of the systems covered by this study led to an updated 2012 study which showed improved performance to an average SCOP of 2.45 for air-source (at H4 boundary) and 2.82 for ground-source.²⁶ The Energy Saving Trust explained that heat pumps clearly are sensitive to design and commissioning, control strategies and user behaviour.

A more recent study released in 2015 in the UK investigated heat pumps installed under the Renewable Heat Premium Payment scheme between 2011 and 2014 and showed an average SCOP of 2.65 for air-source and 2.81 for ground-source.²⁷ Some air-source units were performing with SCOPs at above 3.5 and ground-source above 4, but issues were raised regarding poor performance, including the use of excessive backup resistive heating due to undersized heat pumps, high flow temperatures and limited use of weather compensation.

More recent UK analysis suggested a slight increase in COPs for systems installed under the Renewable Heat Incentive from 2014 onwards, with air-source SCOPs of 2.71 and ground-source SCOPs of 3.07. However, some care should be taken over this data because it considers only a subset of the Renewable Heat Incentive scheme, including hybrid systems and heat pumps in homes not occupied for much of the year.²⁸

²² Miara, M. (2021a, March 3). How well do heat pumps really work in existing buildings? *Innovation 4E*. <https://blog.innovation4e.de/en/2021/03/03/how-well-do-heat-pumps-really-work-in-existing-buildings/>

²³ Miara, M. (2021b, March 17). How well have heat pumps performed in practice in partially refurbished and unrefurbished buildings? *Innovation 4E*. <https://blog.innovation4e.de/en/2021/03/17/how-well-have-heat-pumps-performed-in-practice-in-partially-refurbished-and-unrefurbished-buildings/>

²⁴ O'Reilly, P., O'Shea, M., Hoyne, S. & Hunter G. (2019, March). *Superhomes 2.0. Best Practice Guide for ASHP Retrofit*. Superhomes. <https://lit.ie/getmedia/db76033d-396d-4a27-adbd-2a9e1767e50c/Superhomes-FINAL.pdf>

²⁵ The Energy Saving Trust. (2010, September). *Getting warmer: A field trial of heat pumps*. https://energysavingtrust.org.uk/sites/default/files/EST_Heat_Pump_Trials%20part%202a.pdf

²⁶ The Energy Saving Trust. (2013, August). *The heat is on: Heat pump field trials, phase 2*. [http://www.energysavingtrust.org.uk/sites/default/files/reports/TheHeatisOnweb\(1\).pdf](http://www.energysavingtrust.org.uk/sites/default/files/reports/TheHeatisOnweb(1).pdf)

²⁷ Lowe, R., Summerfield, A., Oikonomou, E., Love, J., Biddulph, P., Gleeson, C., Chiu, L. & Wingfield, J. (2017, March). *Final report on analysis of heat pump data from the renewable heat premium payment (RHPP) scheme*. UCL Energy Institute. https://assets.publishing.service.gov.uk/government/uploads/system/uploads/attachment_data/file/606818/DECC_RHPP_161214_Final_Report_v1-13.pdf

²⁸ Meek, C. (2021). *Heat pumps and UK's decarbonisation: Lessons from an Ofgem dataset of more than 2,000 domestic installations*. Renewable Energy Consumer Code. <https://www.recc.org.uk/pdf/performance-data-research-focused.pdf>

Building on the UK experience, MCS released updated requirements to ensure that heat pumps are sized to meet total heat demand, with supplementary heating only used very carefully and that the impact of radiator sizing on performance was explained to customers.²⁹

There is clearly a need for more measured SCOP data, and the UK is awaiting the outcome of the BEIS-led electrification of heat trial and the release of metering data from the wider Renewable Heat Incentive dataset; publication of these results is due in October 2022 and 2023, respectively.

3.5. Closing the performance gap

Based on this review, there are several considerations to support optimal heat pump performance.

1. Flow temperatures should be as low as possible. Despite the emergence of higher-output heat pumps with better overall COPs, lower flow temperatures will always produce better performance.
2. Weather compensation should always be used to reduce flow temperatures to the lowest possible levels across the year.
3. During design, consideration must always be given to pipework sizing to ensure it is suitable for low flow temperatures.³⁰
4. Unless there is good reason, heat pumps should be sized to provide the entire heat demand of a property and additional resistive heating should be limited.³¹
5. Care should be taken over the use of controls to ensure more continuous heat pump operation.³²
6. Households should be advised regarding low flow temperatures, weather compensation and more continuous heating when having a heat pump installed.

To achieve these elements and good heat pump performance, training and oversight of installers and specifiers are key. We note that the National Standards Authority of Ireland has heat pump installation guidance which covers some of these elements and sizing in particular.³³ The Superhomes project also provides valuable, evidenced examples of how to optimise air-source heat pump performance.³⁴ The availability of skilled installers and the development of heat pump supply chains should be a key focus for the Government of Ireland.

²⁹ MCS Standards. (2013). *Requirements for MCS contractors undertaking the supply, design, installation, set to work, commissioning and handover of microgeneration heat pump systems*. <https://mcscertified.com/wp-content/uploads/2019/08/MIS-3005.pdf>

³⁰ Sizing details here: Heat Geek. (2021a, July). *Shortcut To heating genius! Mass Flow Rate*. <https://www.heatgeek.com/shortcut-to-heating-genius-mass-flow-rate/>

³¹ One historic need for resistive heating has been pasteurization cycles, but some modern heat pumps can produce temperatures which remove the need for this (Vaillant Arotherm Plus).

³² Heat Geek. (2021b, August). *Why not to zone heat pumps!* <https://www.heatgeek.com/why-not-to-zone-heat-pumps/>

³³ NSAI. (2021, March). *Building services - Part 4: Heat pump systems in dwellings*. https://shop.standards.ie/en-ie/standards/s-r-50-4-2021-1210946_saig_nsai_nsai_2932704/

³⁴ O'Reilly et al., 2019.

4. The history of the HLI

Currently, to receive a grant subsidy for the installation of heat pumps, Irish homes need to meet a minimum heat demand target measured in W/K/m². This metric measures the required watts of heat needed per meter square of floor area for every degree Celsius of temperature change. HLI metrics are produced as part of the standard Dwelling Energy Assessment Procedure and allow a simple decision on whether a house is deemed suitable for a heat pump or not.

According to a note by the Sustainable Energy Authority of Ireland (SEAI),³⁵ as part of the technical review for the heat pump grant scheme, a fabric first approach was taken, meaning that before a heat pump is installed, a house must meet a minimum fabric energy efficiency level. As a result, some households are ineligible for heat pump grants, despite being technically suitable for installation of a heat pump. This can present a barrier when rapid heat pump deployment is needed.

Translating the HLI into peak heat demand

For context, at an external temp of -2°C and internal temp of 21 °C; that is, a delta T of 23 °C (peak conditions): at HLI = 2 this is 46W/m² and at HLI = 2.3 this is 52.9W/m². The peak heat demand can be worked out using the equation: heat demand/m² = HLI x delta T (peak).

A heat loss indicator level of 2 W/K/m² was chosen based on the equivalent building fabric performance of 2002 and 2005 for new builds and significant changes, respectively. To provide some flexibility, it can be increased to 2.3 W/K/m² in some circumstances where energy efficiency measures have not been deemed economically feasible but some minimum standards are met.

According to SEAI: ‘An HLI ≤ 2.3 can be accepted where the following requirements are met:³⁶

- Maximum exposed wall U-value 0.37 W/m² K
- Maximum roof U-value 0.16 W/m² K or 0.25 W/m² K where not accessible (e.g. flat roof or rafters)
- Maximum window U-value 2.8 W/m² K* (and double glazed)
- Maximum adjusted infiltration rate of 0.5 ac/h³⁷

Based on U-values in the Dwelling Energy Assessment Procedure Manual,³⁷ the maximum exposed wall U-value of 0.37 W/m² K means that any building with any uninsulated solid walls cannot receive a heat pump grant. The maximum roof U-value of 0.25 W/m² K implies the need for a minimum of approximately 150 mm of insulation.

³⁵ SEAI. (2022c). *Note on the Heat Loss Indicator for Heat Pump Grants*. Shared directly.

³⁶ U-values are also a type of HLI.

³⁷ SEAI. (2012). *Dwelling Energy Assessment Procedure (DEAP)*. https://www.seai.ie/publications/DEAP_Manual.pdf

According to the National Heat Study,³⁸ ‘The HLI threshold of 2 to 2.3 was introduced to avoid adverse consumer reactions during roll-out of a relatively novel technology under the Better Homes Scheme’ (which provides heat pump grants). The idea behind such a standard is to protect households from increases in energy bills if a heat pump is installed to replace a fossil fuel heating system. The suggestion is that inefficient buildings will achieve worse heat pump performance than more efficient ones. If a home can’t achieve HLI 2 but it is somewhere between 2 and 2.3 (and meets the relevant criteria), then there is a requirement to advise the consumer of the threat to energy cost savings if they install a heat pump.

According to the SEAI briefing note referenced previously, and as shown in Table 1 which shows median energy ratings for Irish homes, most existing homes in Ireland do not meet heat pump HLI levels and therefore will not be able to receive grants for heat pumps without further fabric efficiency work.

Table 1. The 50th percentile for fabric performance levels of Building Energy Ratings published in Ireland for existing buildings in Ireland

Median level	HLI
Bungalow	2.81
Detached house	2.42
Semi-detached house	2.20

The reason that, in general, detached homes and bungalows (42% of Irish dwellings)³⁹ have lower HLIs than semi-detached houses is because of their form: they naturally have more external surface area in proportion to their floor area and therefore a higher heat loss per square meter.

And while buildings can be made more energy efficient through insulation, better airtightness and new windows and doors, existing metrics mean that even after what have previously been seen as cost-optimal retrofits (we will come back to this in the following section), some houses would still not meet the HLI target (see Table 2 below).⁴⁰ While the average semi-detached house would meet the HLI = 2 threshold, the average detached house would not, although it would be within the upper 2.3 limit, and the average bungalow does not meet the HLI = 2.3 threshold. Of course, there will also be many below-average homes.

Table 2. When applying the cost-optimal fabric performance to the dwelling, the following average HLI applies

Median level	HLI
Bungalow	2.35
Detached house	2.03
Semi-detached house	1.86

³⁸ SEAI. (2022d, February). *Low Carbon Heating and Cooling Technologies*. <https://www.seai.ie/publications/Low-Carbon-Heating-and-Cooling-Technologies.pdf>

³⁹ Deduced from SEAI, 2022a.

⁴⁰ Taken from SEAI note on heat loss indicator for heat pump grants, shared directly.

4.1. Fabric performance standards for heat pump grants elsewhere

RAP undertook a limited review based on our key markets of interest to consider what fabric efficiency standards for heat pump grants exist elsewhere in Europe:

- In France, we are aware of no standards under 'MaPrimeRénov,' although a bonus may be applied for more efficient buildings.⁴¹ No standards are apparent under their Energy Efficiency Obligation Scheme.
- In Luxembourg, the flow temperature must be a maximum of 35°C or heat pumps with minimum COPs at certain external temperature and flow temperatures must be used. For air-source, COP = 3.1 at air temperature of 2°C, and for ground-source, COP = 4.3 at ground temperature of 4°C, both at 35°C flow temperatures.⁴²
- In the Netherlands there are no fabric requirements, although there is an additional efficiency subsidy if fabric work is carried out alongside the heat pump installation.⁴³
- In Flanders, Belgium, the maximum heat pump output temperature allowed is 55°C, but there are no fabric standards.⁴⁴
- There are no fabric standards in Wallonia, Belgium.⁴⁵
- In Germany, there are no apparent fabric standards.
- In the UK, the only fabric requirement for heat pump grants is that lofts and cavity walls (if present) are insulated, and some exemptions apply.⁴⁶
- In Austria, a maximum flow temperature of 40°C is required, but there are no apparent fabric standards.⁴⁷

Based on our limited review, the fabric standards required for heat pump grants in Ireland appear much stricter than those elsewhere in Europe.

⁴¹ Ministère de l'Économie, des Finances et de la Souveraineté industrielle et numérique, France. (2022, April). *MaPrimeRénov' : la prime pour la rénovation énergétique*. <https://www.economie.gouv.fr/particuliers/prime-renovation-energetique#>

⁴² Portait l'Environnement, Luxembourg. (n.d.). *Pompe à chaleur*. https://environnement.public.lu/dam-assets/documents/emweltprozeduren/personnes_privées/energie/rqb-2022/installations-techniques/poch-2022.pdf

⁴³ Milieu Centraal. (n.d.). *Subsidie warmtepomp*. <https://www.milieucentraal.nl/energie-besparen/energiesubsidies-en-leningen/subsidie-warmtepomp/>

⁴⁴ Vlaanderen. (2022). *Vraag hier Mijn VerbouwPremie aan*. <https://www.vlaanderen.be/bouwen-wonen-en-energie/bouwen-en-verbouwen/premies-en-belastingvoordelen/mijn-verbouwpremie/mijn-verbouwpremie-voor-warmtepomp>

⁴⁵ Wallonie Energie SPW. (2022). *Prime temporaire - Appareil de chauffage et d'eau chaude sanitaire*. <https://energie.wallonie.be/fr/prime-appareil-de-chauffage-et-d-eau-chaude-sanitaire-pour-tous-prime-temporaire.html?IDC=10306>

⁴⁶ Ofgem. (2022). *Boiler upgrade scheme (BUS)*. <https://www.ofgem.gov.uk/environmental-and-social-schemes/boiler-upgrade-scheme-bus/property-owners>

⁴⁷ Kommunal Kredit Public Consulting. (n.d.). *Raus aus Öl und gas*. www.raus-aus-öl.at/efh

5. Energy efficiency and cost-optimality

The National Retrofit Plan ‘aims to achieve the equivalent of 500,000 homes retrofitted to a Building Energy Rating of B2/cost-optimal or carbon equivalent and the installation of 400,000 heat pumps in existing premises to replace older, less efficient heating systems by end-2030.’⁴⁸ The plan, however, recognises that achieving a B2 or HLI level of 2.3 may be cost prohibitive or disruptive and mentions upcoming SEAI research to consider if the HLI level can be extended to 2.6. We are also informed that research to consider HLIs up to 3 is soon to be started.

As mentioned in the previous section, even if some homes were upgraded to what is seen as the current cost-optimal fabric level, many would still not be eligible for heat pump grants.

While cost-optimality and the HLI are separate policy issues with different ‘owners’ in government, this section considers the issue of cost-optimality and suggests why greater consideration of the importance of heat pumps might have value. While cost-optimality calculations are a requirement of EU law, we argue that the Irish government's wider approach to cost-optimality in buildings should focus primarily on heat pumps, heat networks and the importance of low flow temperatures. We also argue that such calculations should also consider wider energy system impacts, consumer bills, health and comfort.

5.1. The importance of energy efficiency

The energy efficiency first principle is one of the central pillars of EU energy policy, and there are multiple reasons why energy efficiency should be a priority for heat decarbonisation. Fabric energy efficiency measures can:

1. Directly reduce the greenhouse gas emissions of buildings by reducing the demand for heat.
2. Reduce building heating costs by lowering the demand for heat.
3. Make buildings more suitable for low-carbon heat sources which run at lower flow temperatures by limiting the required capacity of emitters and heat systems. In some cases, it is possible that an efficiency renovation could make heating systems suitable for heat pump flow temperatures without changes to emitters. To be heated at the same flow temperature, a building with an HLI of 3 would need 1.5X the emitter output of a building with an HLI of 2, a modification which can take up space and add cost.
4. Deliver comfort benefits by allowing buildings to be maintained at a higher average internal temperature at lower cost.
5. Through reducing the speed at which buildings cool, allow buildings to be treated as thermal stores and be integrated into smart energy systems. If building heat and hot water demand can be shifted and time-of-use tariffs used, running costs can be reduced.⁴⁹

⁴⁸ Government of Ireland, 2022.

⁴⁹ Rosenow, J. & Lowes, R. (2020, March). *Heating without the hot air: Principles for smart heat electrification*. Regulatory Assistance Project. <https://www.raponline.org/knowledge-center/heating-without-hot-air-principles-smart-heat-electrification/>

6. Reduce the wider system impacts of electrification by limiting total peak heat demand.

The definition of cost-optimal energy efficiency is based on reporting and analysis requirements under the EU's Energy Performance of Buildings Directive (EPBD). The definition in the EPBD for calculating cost-optimality, where cost-optimal level means the energy performance level which leads to the lowest cost during the estimated economic lifecycle,⁵⁰ doesn't directly consider decarbonisation. While understanding cost-optimality is often valuable, such a limited view of cost-optimality is unlikely to be sufficient in the context of the need for rapid decarbonisation and rapid heat pump deployment. Calculations can become outdated if energy prices change from projected levels, and calculations may not focus specifically on the direction of future development, which is cost-effective decarbonisation.

5.2. Cost-optimality and HLI level

A 2018 analysis by AECOM for the Irish government provided updated cost-optimality figures for energy efficiency retrofit measures.⁵¹ Based on the analysis, the SEAI explains that 'The cost-optimal level is a primary energy performance of less than 125 kWh/m²/yr (B2 BER) when calculated using DEAP (dwelling energy assessment procedure) or upgrade of ceiling insulation and heating system.'⁵²

Table 3⁵³ shows the U-values, air leakage rates and thermal bridging that the AECOM analysis suggests⁵⁴ would be cost-optimal for homes in Ireland. Table 2, shown previously, describes what the Irish housing stock would look like on average from an HLI perspective if all homes were upgraded to these cost-optimal levels.

Table 3. These U-values and leakage and bridging rates were found to be cost-optimal in an AECOM study for SEAI

Wall U-value (W/m ² K)	0.31 Cavity 0.37 Solid
Roof U-value (W/m ² K)	0.13
Window U-value (W/m ² K)	2.8
Infiltration – equivalent to	10 m ³ /h/m ²
Thermal bridging Y-value	0.15

⁵⁰ European Commission. (2010, June). *Directive 2010/31/EU of the European Parliament and of the Council of 19 May 2010 on the energy performance of buildings (recast)*. <https://eur-lex.europa.eu/legal-content/EN/TXT/PDF/?uri=CELEX:32010L0031&from=EN>

⁵¹ Government of Ireland. (2018, February). *Cost Optimal Residential Report Ireland 2018*. <https://www.gov.ie/en/publication/8b915-cost-optimal-residential-report-ireland-2018/>

⁵² SEAI. (n.d.). *Nearly Zero Energy Building Standard*. <https://www.seai.ie/business-and-public-sector/standards/nearly-zero-energy-building-standard/>

⁵³ Taken from SEAI note on heat loss indicator for heat pump grants, shared directly.

⁵⁴ Government of Ireland, 2018.

Even if houses were upgraded to cost-optimal levels, many still wouldn't meet the HLI criterion of 2. While the majority would be within the extended HLI 2.3 level following cost-optimal retrofits, most bungalows would not. It could be a significant issue for heat pump deployment if the promoted levels of fabric efficiency are not aligned with the required fabric efficiency level needed for heat pump grants.

5.3. Cost-optimality in the context of decarbonisation

As shown below in Figure 6, the National Heat Study analysis suggested that most homes in Ireland were technically suitable for heat pumps, and heat pumps are seen as a core element of heat decarbonization.⁵⁵ These results are from a whole-energy-system analysis in the context of lowest-cost decarbonisation.

This technical suitability is based on a maximum peak heat demand above 100w/m² (HLI = 4.5) being deemed unsuitable for heat pumps; the heat demand limit is based on a maximum identified by SEAI from the Microgeneration Certification Scheme in their emitter guidance.⁵⁶ However, MCS has confirmed directly with RAP that this is not a technical limit for heat pumps but a design consideration.⁵⁷ Therefore, buildings with a peak heat demand beyond 100w/m² may be technically suitable for heat pumps and the 100w/m² threshold may be arbitrary.

Figure 6. Technical potential for low-carbon heating systems in Irish residential buildings

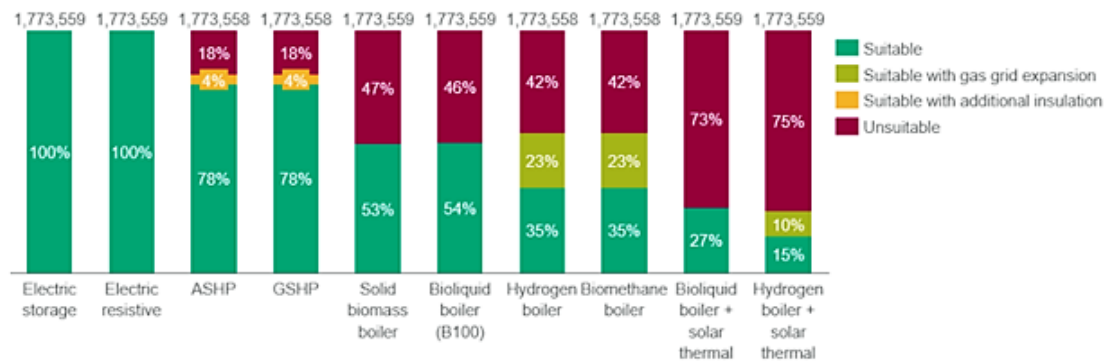

Source: SEAI. (2022d, February). *Low Carbon Heating and Cooling Technologies*. Pg. 10.

⁵⁵ SEAI, 2022d. Pg. 10.

⁵⁶ SEAI, 2022d.

⁵⁷ Personal communication between RAP and MCS.

Figure 7, also from the heat study analysis, compares the HLI level to peak heat loss.⁵⁸ The added red arrow indicates the current gap between the maximum HLI and the suggested technical potential of low-temperature heat pumps.⁵⁹ Clearly, many homes are seen to be technically suitable for heat pumps, yet are unable to receive grant funding.

Figure 7. The relationship between HLI and peak heat loss, with dotted lines showing current HLI 2 and 2.3 levels and the 100W/m² level, which is assumed to be the maximum heat loss suitable for low-temperature heat pumps

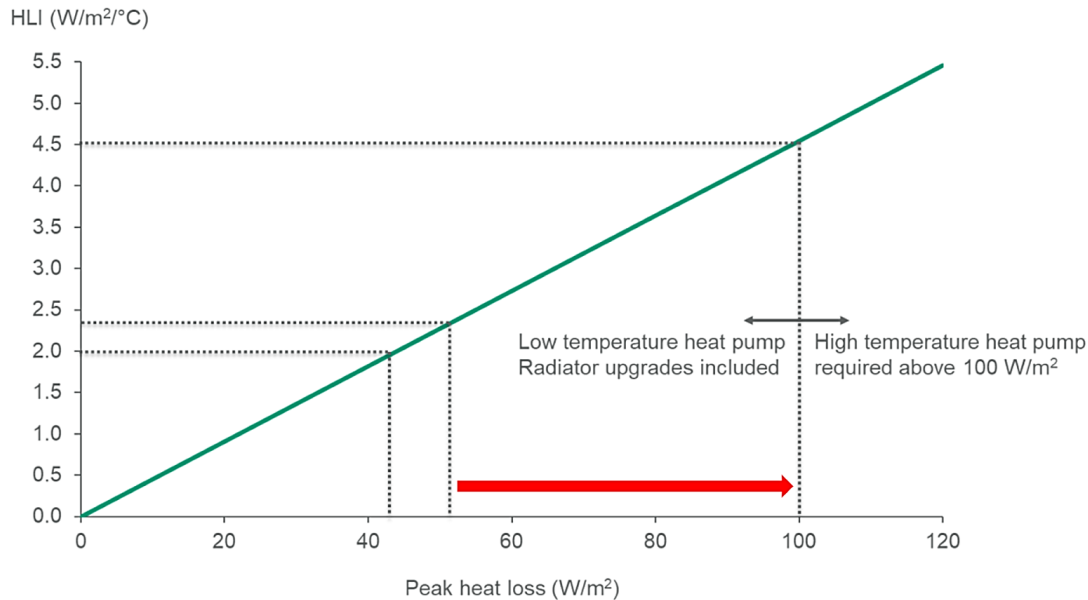

Source: SEAI. (2022d, February). *Low Carbon Heating and Cooling Technologies*. Pg. 49. Note: Red arrow has been added to indicate gap between maximum HLI and suggested technical suitability.

The cost of switching to a heat pump from a fossil fuel heating system, particularly for the first-time switch, is normally more than replacing a fossil fuel boiler.⁶⁰ Yet, as discussed previously, heat pump running costs can be similar to or lower than fossil fuel heating. Overall however, we expect the life-cycle costs (i.e. the combined capital and operating costs) of the first-time switch to a heat pump to be more than the fossil fuel equivalent, primarily due to emitter and pipework upgrades and external modifications.

Naturally, if the life-cycle costs of a heating system (such as a heat pump) are more than a fossil fuel heating system, if a heat pump becomes the cost comparator, greater building fabric efficiency will be cost-effective. Therefore, it may make sense to consider cost-optimality in the context of a scenario where heat pumps are the go-to standard for heating systems.

⁵⁸ SEAI, 2022d. Pg. 49.

⁵⁹ 'Low-temperature heat pump' is not defined.

⁶⁰ See section 3.2 here for more information: Lowes, R., Rosenow, J., Scott, D., Sunderland, L., Thomas, S., Graf, A., Baton, M. et al. (2022, March). *The perfect fit: Shaping the Fit for 55 package to drive a climate-compatible heat pump market*. Regulator Assistance Project. <https://www.raonline.org/knowledge-center/the-perfect-fit-shaping-the-fit-for-55-package-to-drive-a-climate-compatible-heat-pump-market/>

The National Heat Study did consider energy efficiency retrofits with air-source heat pumps as the heating technology. This analysis, displayed in Figure 8, showed that at a building level, energy efficiency measures were cost-effective for many buildings with heat pumps.⁶¹ As expected, the analysis showed that by allowing longer payback periods for measures, more measures would be included.

Figure 8. HLI bands across the residential sector if the whole stock had uptake of each energy efficiency package

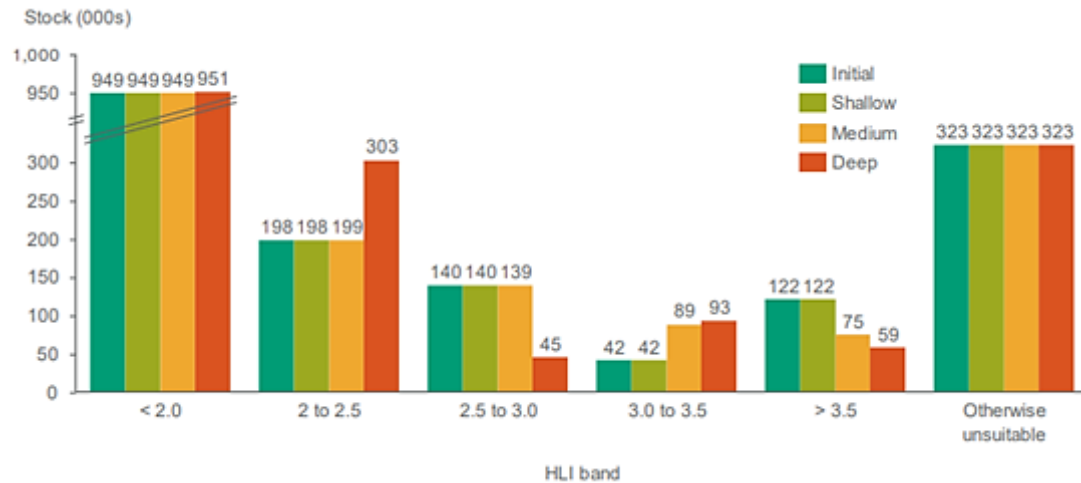

Source: SEAI. (2022d, February). *Low Carbon Heating and Cooling Technologies*. Pg. 50. Note: Shallow, deep and medium is based on time to payback — shallow is three years, and deep is 10 years.

However, what the analysis did not indicate was which measures were cost-effective (in terms of household payback), which were not and how building type affected this. The analysis also suggested that cost-effectiveness measures would not necessarily take buildings below the HLI 2.3 level, again indicating that the HLI requirement may need to be relaxed. It is worth noting that the recent significant increase in energy prices will have had a significant impact on payback calculations, and there is deep uncertainty over future prices.

UK BEIS commissioned a similar but much more detailed analysis on ‘cost-optimal domestic electrification’ (CODE), with a headline that explained ‘Decarbonised electricity offers the promise of very low or even zero-carbon heating for homes — without necessarily carrying out extensive deep retrofit work. This project shows that Great Britain’s homes can convert to electric heating at a cost far lower than the accepted wisdom. This can be achieved with no threat to comfort, and greenhouse gas emissions will fall very dramatically as a result’.⁶²

Basically, what the CODE analysis showed was that from a household perspective over a 15-year timeline, solid wall insulation (SWI) was rarely seen to be cost-effective, and the use of high-temperature heat pumps would be better over the 15-year period. However, SWI clearly has an impact of longer than 15 years and can have very significant comfort benefits. It will also provide a perpetual benefit in terms of energy consumption and, therefore, bills and can support lower flow temperatures and therefore higher COPs. Using Great Britain’s housing stock in the analysis also means

⁶¹ SEAI, 2022d. With ASHP as the heating technology. P50.

⁶² BEIS, 2021.

that detached properties and bungalows, which are much more prevalent in Ireland, are less well represented by the analysis.

Overall, the current cost-optimality metric required under EU law is not well aligned with Ireland's long-term energy strategy. If the HLI requirements are to be relaxed, this becomes less of an issue. However, as most Irish buildings are expected to be heated with heat pumps in future, a much greater consideration of optimal fabric energy efficiency in relation to heat pumps may have value.

5.4. Systemwide impacts and considerations

The energy efficiency of buildings can have impacts beyond the building level. For example, in a world of high heat pump penetration, a less efficient building stock would lead to a higher total peak heat demand, which would require higher electricity network capacity and higher electricity generation capacity. More efficient buildings would lead to a lower peak heat demand and therefore lower system costs. Another benefit of greater levels of energy efficiency would be that buildings could be heated more flexibly as they would be better thermal stores; again, this could have systemic value.⁶³ While increasing electricity system capacity and throughput is generally seen as a requirement of decarbonisation, limiting the capacity increases could have obvious value.

The electrification of other sectors could also impact or perhaps support heat decarbonisation. These sorts of issues and the wider impacts of energy efficiency can only be considered using energy system models and are missed by simple cost-optimal calculations.

A continentwide example of this sort of analysis which considered renewable energy resource and therefore future energy costs (which vary by location) suggests that, for areas such as Ireland which have a large renewable energy resource and therefore likely low energy costs, the cost-effective energy demand reduction may be quite low.⁶⁴ This example of analysis, while interesting, is pure modelling and based on assumptions such as perfect investment decisions.

As described in their methodology report,⁶⁵ the UK Climate Change Committee takes a holistic approach to levels of energy efficiency, considering cost-effectiveness, wider benefits and consumer preferences. As a result of this approach, the committee suggests around half of all solid-walled homes and nearly all lofts and cavity walls should be insulated.⁶⁶ This would mean that a significant number of UK homes would be heated with heat pumps but keep uninsulated solid walls.

⁶³ Rosenow & Lowes, 2020.

⁶⁴ Zeyen, E., Hagenmeyer, V. & Brown, T. (2021, September). Mitigating heat demand peaks in buildings in a highly renewable European energy system. *Energy*, Volume 231. 120784, ISSN 0360-5442. <https://doi.org/10.1016/j.energy.2021.120784>

⁶⁵ Committee on Climate Change. (2020a, December). *The Sixth Carbon Budget Methodology Report*. <https://www.theccc.org.uk/wp-content/uploads/2020/12/The-Sixth-Carbon-Budget-Methodology-Report.pdf>

⁶⁶ Committee on Climate Change. (2020a, December). *The Sixth Carbon Budget – Buildings*. <https://www.theccc.org.uk/wp-content/uploads/2020/12/Sector-summary-Buildings.pdf>

Timed versus continuous operation

Because heat pumps run best at lower flow temperatures than those produced by combustion-based heating systems, they tend to be used more continuously than combustion-based heating. However, UK research shows that this is not always the case and they can be used on more of a timed basis.⁶⁷ In general, if a building is heated more continuously, it will have a higher annual heat demand however, lower flow temperatures can be used, producing a higher SCOP. Vice versa, if a building is heated with a heat pump on more of a timed basis, overall heat demand may be lower, but the SCOP may also be lower, as higher flow temperatures may be needed. Therefore, it is not clear which will lead to lower costs. The impact of more continuous use is considered in the analysis by BOC mentioned in this section.

Overall, increases to building fabric efficiency offer multiple benefits and are undoubtedly a requirement for decarbonisation. There is, however, an important trade-off between the capital cost and the benefits (which can be complicated to calculate). As the costs of renewable electricity generation have fallen, the expected value of energy efficiency has been reduced in the world of energy system models.

However, real-world prices have of course increased significantly, and energy efficiency offers a very valuable hedge against volatile energy prices in any scenario.

5.5. Heat pump running costs

Despite the continued use of the HLI, analysis by the SEAI⁶⁸ from 2018 suggests that for HLI levels between 2 and 2.75, a heat pump at a COP of 3 would be cheaper to run than oil and mains gas.⁶⁹ Separate analysis by consultants Byrne Ó Cléirigh (BOC)⁷⁰ suggests that for detached and semi-detached buildings, heat pumps should generally be cheaper to run than oil boilers but more expensive than gas boilers. We have some concerns about this analysis, including the assumed COP of heat pumps (which appears low), the assumed efficiency of the boiler (very high at a level which would require low flow temperatures) and operating schedules. The assumptions BOC use on additional rebound effects⁷¹ beyond those associated with more continuous use of heating (see sidebar above)⁷² may also need to be dismissed, as we have seen no evidence of such a response following heat pump installation. We suggest that the BOC calculations be reworked in light of recent energy costs and more up-to-date heat pump performance and use data, as they may be overly pessimistic on heat pump running costs.

⁶⁷ Love, J., Smith, A., Watson, S., Oikonomou, E., Summerfield, A., Gleeson, C. Biddulph, P., et al. (2017, October) The addition of heat pump electricity load profiles to GB electricity demand: Evidence from a heat pump field trial. *Applied Energy*, Volume 204. Pages 332-342. ISSN 0306-2619. <https://doi.org/10.1016/j.apenergy.2017.07.026>

⁶⁸ Better Energy Homes. (2018). *Heat Loss Indicator* [Presentation]. Shared directly with RAP.

⁶⁹ N.B. According to the presentation, the heat pump would be running 24 hours a day but would use an off-peak rate overnight.

⁷⁰ Shared directly with RAP.

⁷¹ This refers to the 'stacking' of rebound effects referred to in comments from BOC. We are not suggesting that continuous operating of heating will not increase overall thermal energy demand but do not see why an additional rebound effect should be stacked on top of this.

⁷² Nicola. (2022, January 12). Will heating your house constantly use more energy? *Energy Thoughts and Surprises* [Blog]. <https://energy-surprises.blogspot.com/2022/01/will-heating-your-house-constantly-use.html>

Of course, all analysis also needs to be considered in the context of volatile and increasing energy prices. According to SEAI data,⁷³ the cost of oil has increased by more than the cost of gas which has itself increased more than the cost of electricity. Therefore, the relative economics of heat pumps have improved, and this price change will not have been included in the BOC or National Heat Study analysis.

Our inputting of more recent energy costs⁷⁴ into the BOC model suggests that heat pumps are now cheaper to operate than oil systems in both detached and semi-detached properties and cheaper than gas in semi-detached properties.⁷⁵ Fuel prices do vary, and of course the impact of further changes to Ireland's carbon tax on heating fuels should be considered.⁷⁶ Overall, however, the falling cost of renewable electricity (if reflected in market prices) and rising carbon prices means that heat pumps are likely to become more cost-effective over time.

5.6. Section summary

Measuring the cost-effectiveness of energy efficiency is not straightforward because costs and context change. Overall, for Ireland's energy transition plans, it makes sense to consider building energy efficiency cost-effectiveness in the combined context of:

- Heat pumps, the key heat decarbonisation technology.
- Wider energy system impacts and peak electricity demand, things that can only be considered by energy system modelling.
- Ongoing running costs, comfort and resilience for households.

Political judgement will be needed when considering these elements together, because there are many technological outcomes and possibilities, but the importance of energy bills, health and comfort means this is also an important social decision. Cost-optimal calculations are carried out every five years, and we note the current development of the upcoming 2023 cost-optimal calculations and the potential for the cost-optimal building energy rating to reach A3 level. Meeting the A3 level could drive more thorough fabric upgrades, meaning more homes, once upgraded, would sit within the current HLI threshold for heat pump grants.

⁷³ SEAI. (2022e, October). *Domestic Fuel Cost Comparison of Energy Costs – Quarterly*. <https://www.seai.ie/publications/Domestic-Fuel-Cost-Comparison.pdf>

⁷⁴ SEAI, 2022e.

⁷⁵ N.B. On running costs, heat pumps will even outperform brand-new, efficient oil boilers, though not new, highly efficient gas boilers. However, we question the assumed boiler efficiency and have not included the 'rebound.'

⁷⁶ https://www.citizensinformation.ie/en/money_and_tax/tax/motor_carbon_other_taxes/carbon_tax.html

6. The impact of HLI on heat pump bills

Much of the data we have presented is based on the technical performance of heat pumps and buildings. There are, however, important basic considerations regarding heat pump running costs:

- A less efficient building will use more energy overall compared to a same-sized, more efficient building heated to the same temperature.
- A building heated to a higher temperature will have a higher heat demand compared to one heated at a lower temperature.
- A heat pump using lower flow temperatures will consume less energy than if it used higher flow temperatures.
- A building heated with lower flow temperatures will need higher-output heat emitters than one heated with combustion.
- Subject to everything else remaining the same, a building heated to a constant level of comfort will use more energy than one heated periodically.

All these elements can have a significant impact on heating bills, but the HLI only deals with the first point. Installation, configuration and use by householders will affect all the other points.

Analysis of the in situ performance of heat pumps in Ireland is limited. The case study data below in Figure 9, from a variety of houses both in and out of the HLI criteria with heat pumps, does not provide evidence of a direct relationship between HLI and electricity use and, therefore, running costs.⁷⁷ This is a small and limited sample across a partial HLI range, and better in situ monitoring of heat pumps would have obvious value. Nonetheless, it shouldn't be assumed that a heat pump in a less efficient building will lead to poorer performance than in a more efficient building. Developing more in situ heat-pump-performance data should be a priority for those working on heat pump deployment in Ireland.

Figure 9. HLI versus measured electricity demand for 17 Irish houses

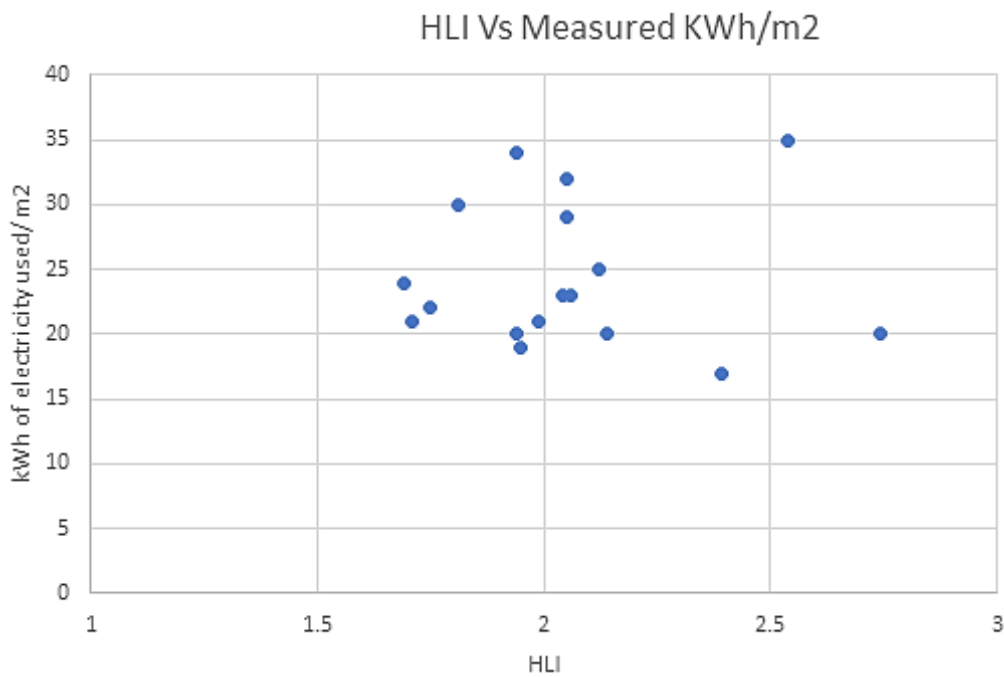

Source: Tipperary Energy data

The current HLI limit effectively de-risks heat pump deployment. In more efficient houses, bills will always be lower. However, the limit also means that the room for error associated with heat pump installations, which is greater for heat pumps than fossil fuel heating systems because of the specificity of flow temperatures and sizing, is limited, something which could have value for ensuring that heat pumps have a good reputation among consumers.

Beyond this de-risking, however, the HLI limit itself bears no direct relation to heat pump running costs compared to other types of fuel. Therefore, we would suggest that another metric which can better guarantee heat pump performance should be used: flow temperatures. Subject to proper design and installation, a maximum flow temperature limit would always ensure a heat pump achieves good COP performance.

⁷⁷ Tipperary Energy data

We do, however, note that with modern heat pumps achieving acceptable COPs at higher flow temperatures, there may also be a case for linking the maximum flow temperature to the COP of a particular product, subject to testing. Using this approach, a required SCOP of, say, 3.5 could be chosen by the government, and the maximum flow temperature could be linked to the proven performance of that product. This approach would require further testing and detailed policy consideration but could support both rapid heat pump deployment and innovation. Such an approach is already used in Luxembourg, as described in section 4.1.

7. Conclusions

The decarbonisation of buildings in Ireland requires a rapid roll-out of heat pumps, but the transformation is technologically complex and requires protection of and buy-in from households. The current HLI requirements mean that many houses, in particular bungalows, cannot receive grants for heat pumps without energy efficiency upgrades. There is undoubtedly merit in increasing the energy efficiency of the Irish housing stock, but the current HLI criterion does not necessarily protect consumers in the way it was envisaged to.

The current application of cost-optimal fabric energy efficiency improvements in Ireland also leads to some policy confusion. Despite the need for mass heat pump deployment, the current cost-optimal standard, if followed, would mean some houses still wouldn't meet the HLI threshold. The method for calculating cost-optimality also does not consider wider energy system impacts, such as reductions in peak demand and flexibility offered by more efficient buildings. Overall, we make three suggestions.

1. The continued use of the HLI metric as a requirement for heat pump grants should be considered. We note the current pilots to install heat pumps in homes with an HLI above 2.3 to inform a decision on the HLI. If more rapid policy reform is wanted, the HLI threshold could be increased in the short term, with additional advice offered to households. It does not seem unreasonable that a household which is deemed to be technically suitable for a heat pump should be offered a grant if they are advised that bills may increase. In reality, bills may decrease, and significantly, if a heat pump system is combined with solar photovoltaic panels, which are expected to rapidly grow in number.⁷⁸

2. Flow temperatures and heat pump performance should be considered as the primary metrics for grants. Among the most important determining factors for good and cost-effective heat pump performance are flow temperature and heat pump sizing. The HLI requirement could be replaced with a maximum flow temperature requirement (of, for example, 45°C) alongside the need for evidence of system sizing, something already recommended in the SEAI implementation guide.⁷⁹ To consider heat pump innovation and better performance at higher temperatures, the flow temperature requirement could be linked to specific product performance. For example, a SCOP of 3.5 could be deemed the minimum and the flow temperature of the product could be set to ensure performance was at least 3.5.

⁷⁸ SEAI. (2020a, April). *Renewable Energy in Ireland – 2020 update*. <https://www.seai.ie/publications/2020-Renewable-Energy-in-Ireland-Report.pdf>

⁷⁹ SEAI. (2020b, August). *Heat Pumps – Implementation Guide*. <https://www.seai.ie/publications/Heat-Pump-Implementation-Guide.pdf>

3. With regard to fabric energy efficiency requirements, a more simplistic approach based on minimum standards may have value. For example, heat pump grants could be offered only in situations where lofts and cavity walls are insulated and windows and doors are double glazed with sensible airtightness measures. A similar approach based on minimum standards is used for the UK Boiler Upgrade Scheme.⁸⁰ A judgement on whether uninsulated solid walls should be included could be considered in the future when more performance data is available. To reduce risk and assess performance in these homes, a requirement for COP metering could be introduced and grant funded. This would also provide extremely valuable performance data.

Our proposals for reform should not detract from the importance of fabric energy efficiency. However, the speed implied by the goal of net zero in 2050, innovation in heat pump performance and the fact that heat pumps may be able to reduce bills suggests that speedier heat pump deployment supported by a restructuring of grant requirements should be considered. All of this should be considered alongside the need for consumer protection from poor heat pump installations to shield consumers from high bills and ensure the mass roll-out of heat pumps is smooth. A focus on installer availability, skills and supply chains would have obvious value.

4. A wider heat pump innovation and testing strategy will also have value for Ireland. Further research on the in situ performance of heat pumps in Ireland and analysis of best available technology would be useful, as available data is limited. Based on up-to-date in situ analysis, a continuously updated heating cost model, which includes heat pumps and other technologies, would also likely be extremely valuable for citizens and policymakers.

⁸⁰ Ofgem. (2022b, July). *Boiler Upgrade Scheme: Guidance for Installers*. <https://www.ofgem.gov.uk/publications/boiler-upgrade-scheme-guidance-installers>



RAP[®]

Energy Solutions for a Changing World

Regulatory Assistance Project (RAP)[®]
Belgium · China · Germany · India · United States

Rue de la Science 23
B – 1040 Brussels
Belgium

+32 2-789-3012
info@raponline.org
raponline.org

© Regulatory Assistance Project (RAP)[®]. This work is licensed under a Creative Commons Attribution-NonCommercial License (CC BY-NC 4.0).